

**Deep Cycle SLA Battery**

**DC SERIES**

DC (Deep cycle) Series batteries are designed for deep discharge application, with special chemical formula for plates active paste material, slightly stronger electrolyte and low temperature design, which can withstand repeated deep cyclic application, such as Solar Energy System, Golf Trolley, Electric

**Application**

- Solar Energy System
- Golf Cars and Buggies
- Electric Powered Vehicles
- Wheel Chairs
- Power Tools
- Electric Powered Toys
- Control System
- Vacuum Cleaners
- Medical Equipments
- UPS

**General Features**

- Sealed and maintenance free operation.
- Non-Spillable construction design.
- ABS containers and covers(UL94HB, UL94V-0) optional.
- Safety valve installation for explosion proof.
- High quality and high reliability.
- Exceptional deep discharge recovery performance.
- Low self discharge characteristic.
- Flexibility design for multiple install positions.

**Construction**

- Component .....Raw material
- Positive .....Lead dioxide
- Negative .....Lead
- Container .....ABS
- Cover .....ABS
- Sealant .....Epoxy Resin
- Safety valve ....EPDR
- Terminal .....Copper
- Separator .....Fibre glass
- Electrolyte .....Sulfuric acid

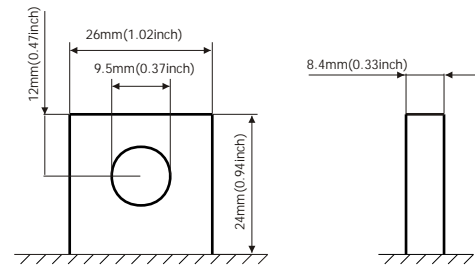

**Terminal Dimensions**

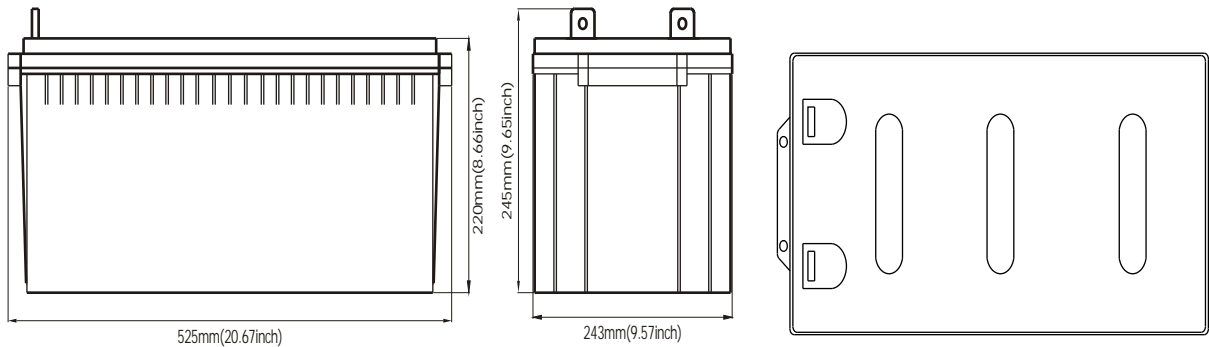

Battery Model	DC 12-180			
Designed Cycle Life	> 350 cycles @ -0.5CA to 9.6V			
Capacity(25°C)	20HR(9.1A,1.75V)	10HR(18A,1.75V)	5HR(30.6A,1.75V)	1HR(117A,1.75V)
	182AH	180AH	153AH	117AH
Dimensions	Length	Width	Height	Total Height
	525mm(20.67inch)	243mm(9.57inch)	220mm(8.66inch)	245mm(9.65inch)
Approx. Weight	58Kg (127.89 lbs)			
Internal Resistance	Full charged at 25°C: 0.004 Ohm			
Self Discharge	3% of capacity declined per month at (25°C)			
Capacity Affected by Temp.(20HR)	40°C	25°C	0°C	-15°C
	102%	100%	85%	65%
Charge Voltage(25°C)	Cycle use		Float use	
	14.4-15V(-30mV/ °C), max. Current: 45A		13.6-13.8V(-20mV/ °C)	

Deep Cycle SLA Battery

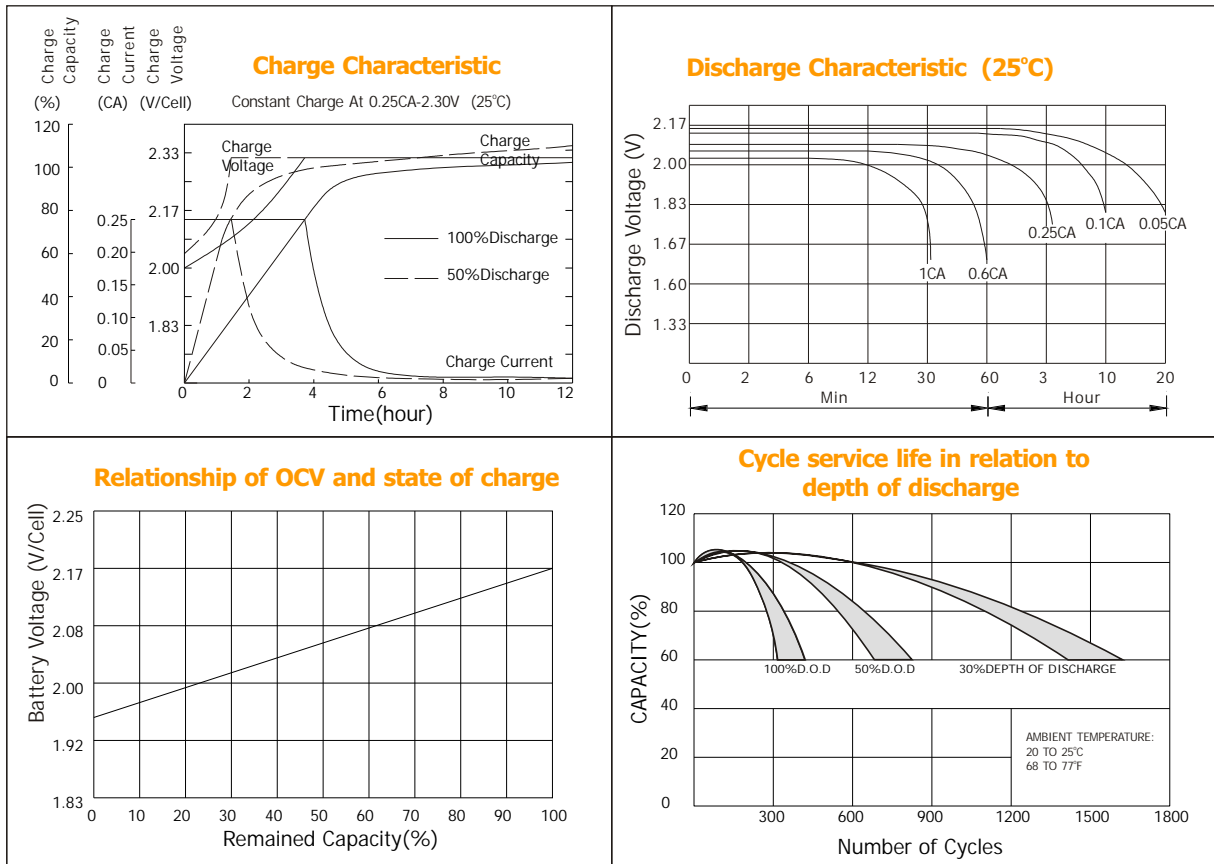

Constant current discharge ratings-amperes at 25°C

F. V/Time	5MIN	10MIN	15MIN	30MIN	1HR	3HR	5HR	10HR	20HR
1.60V	787	490	369	225	140	57.3	35.0	19.1	10.3
1.67V	739	465	355	215	139	55.1	34.3	18.9	9.94
1.70V	677	448	347	196	134	51.4	33.5	18.8	9.79
1.75V	664	434	336	186	128	49.7	32.8	18.7	9.53
1.80V	594	414	305	172	120	47.7	30.8	18.4	9.27
1.85V	524	395	274	159	112	46.0	28.9	18.1	9.01

Constant power discharge ratings-watts at 25°C

F. V/Time	5MIN	10MIN	15MIN	30MIN	1HR	3HR	5HR	10HR	20HR
1.60V	1381	884	674	406	254	109	59.2	39.2	20.6
1.67V	1332	862	666	397	252	106	58.9	38.9	19.8
1.70V	1255	853	660	372	247	101	58.1	38.7	19.6
1.75V	1263	851	655	361	243	98.8	57.6	38.2	19.1
1.80V	1155	838	607	344	229	95.9	55.8	37.7	18.6
1.85V	1048	795	551	322	215	93.0	54.1	37.2	17.9

