

Gel Series SLA Battery

Gel Series

Gel series batteries are designed to meet the requirements of frequent cyclic and high temperature applications such as broadband, PVs etc through up-to-date gel technologies. BOSFA Gel batteries uses German origin high purity fumed silica to form sulfuric acid thixotropic Gel and fills to the batteries with vacuum to ensure the fully penetration of electrolyte through separators and plates pastes.

Application

- Alarm System
- Cable Television
- Communication Equipment
- Control Equipment
- Security System
- Medical Equipment
- UPS
- Power tools
- Emergency Power System
- Toys

General Features

- Sealed and maintenance free operation.
- Non-Spillable construction design.
- ABS containers and covers(UL94HB, UL94V-0) optional.
- Safety valve installation for explosion proof.
- High quality and high reliability.
- Exceptional deep discharge recovery performance.
- Low self discharge characteristic.
- Flexibility design for multiple install positions.

Construction

- | | | | |
|-----------|-------------------|--------------|------------------------------------|
| Component |Raw material | Sealant |Epoxy Resin |
| Positive |Lead dioxide | Safety valve |EPDR |
| Negative |Lead | Terminal |Copper |
| Container |ABS | Separator |Macromolecule polymer |
| Cover |ABS | Electrolyte |sulfuric acid thixotropic Gel |

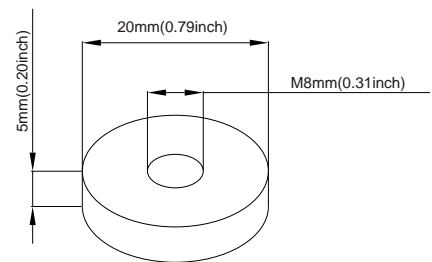

Terminal Dimensions

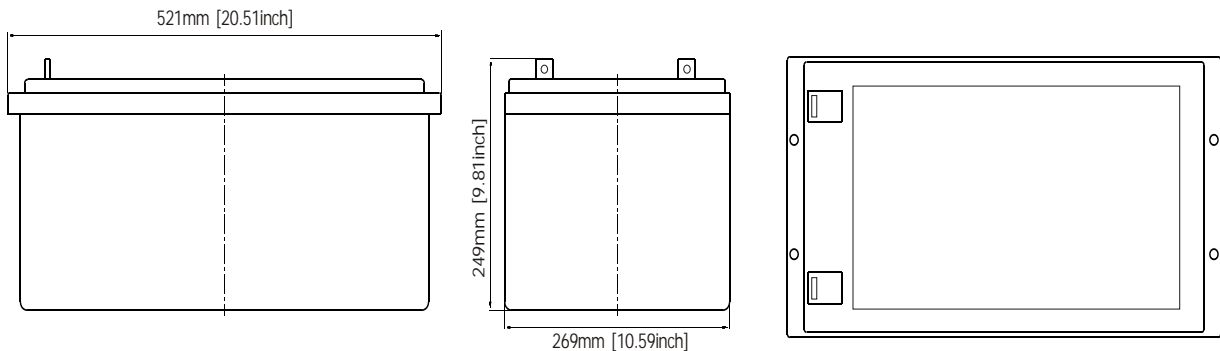

Battery Model	GEL12-250			
Designed Floating Life	12 Years (Floating) or > 750 Cycles @ 50% D.O.D			
Capacity(25°C)	20HR(12.7A,1.75V)	10HR(25A,1.75V)	5HR(42.5A,1.75V)	1HR(150A,1.75V)
	254AH	250AH	212.5AH	150AH
Dimensions	Length	Width	Height	Total Height
	520mm [20.47inch]	268mm [10.55inch]	220mm [8.67inch]	249mm [9.81inch]
Approx. Weight	74Kg (163.17 lbs)			
Internal Resistance	Full charged at 25°C: 0.004 Ohm			
Self Discharge	3% of capacity declined per month at (25°C)			
Capacity Affected by Temp.(20HR)	40°C	25°C	0°C	-15°C
	102%	100%	85%	65%
Charge Voltage(25°C)	Cycle use		Float use	
	14.4-15V(-30mV/ °C), max. Current: 50A		13.6-13.8V(-20mV/ °C)	

Gel Series SLA Battery

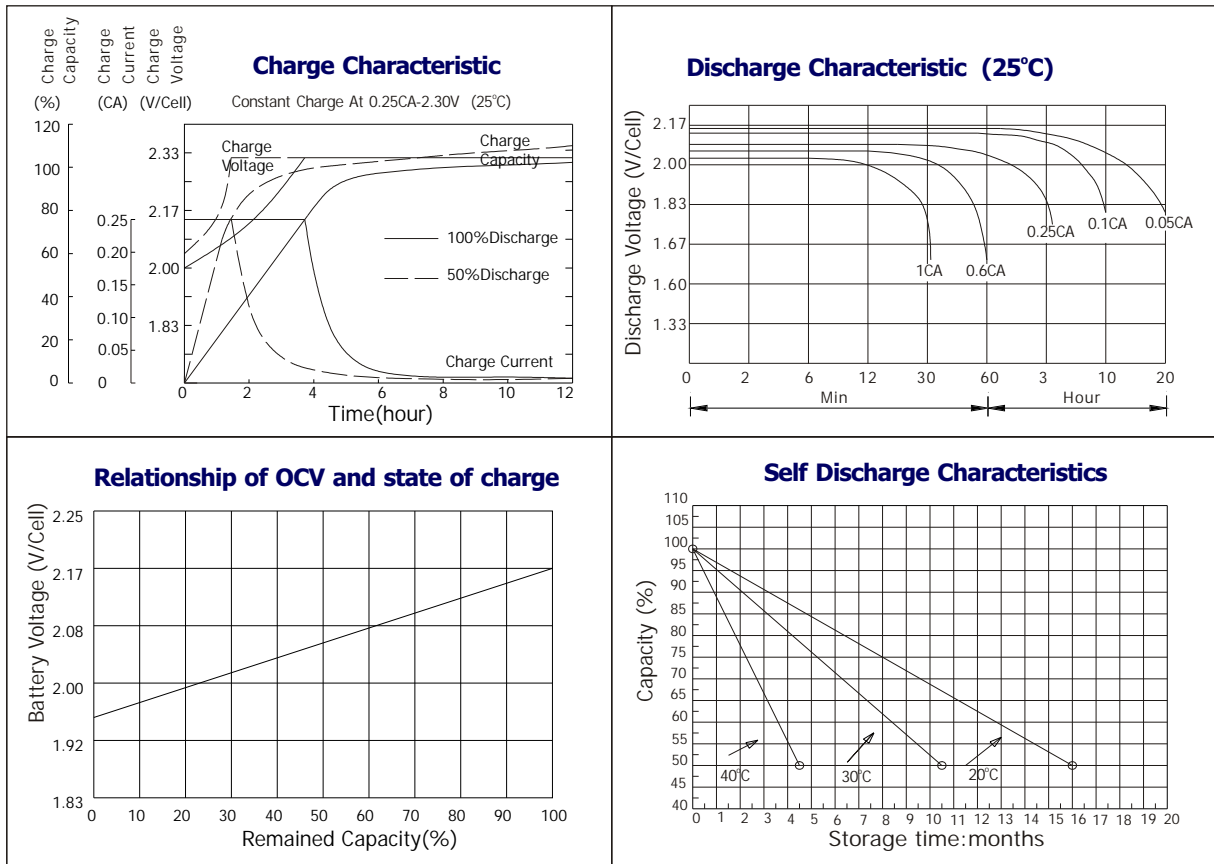

Constant current discharge ratings-amperes at 25°C

F. V/Time	5MIN	10MIN	15MIN	30MIN	1HR	3HR	5HR	10HR	20HR
1.60V	875	600	438	263	165	68.3	47.7	26.5	13.2
1.67V	788	548	425	255	165	68.0	47.3	26.1	13.1
1.70V	748	528	410	250	164	68.0	47.3	25.9	13.1
1.75V	665	488	388	245	163	67.5	46.9	25.5	13.1
1.80V	600	453	370	238	161	67.3	46.5	25.0	12.6
1.85V	455	373	320	219	159	67.0	46.2	24.6	11.9

Constant power discharge ratings-watts at 25°C

F. V/Time	5MIN	10MIN	15MIN	30MIN	1HR	3HR	5HR	10HR	20HR
1.60V	1443	995	775	495	325	131	91.3	53.0	26.4
1.67V	1368	983	768	485	314	131	91.3	52.2	26.3
1.70V	1278	958	755	473	306	131	91.3	51.8	26.3
1.75V	1190	895	710	460	303	129	90.3	50.9	26.1
1.80V	1068	833	668	448	298	127	88.8	50.0	25.2
1.85V	855	690	583	410	295	127	87.5	49.2	23.7

