

OPzS Series SLA Battery

Opzs Series

Bosfa Opzs Series Lead Acid batteries are designed with a combination of die-casting Tubular positive framework and superfluous electrolyte technologies to offer a very high lever of reliability and a long service life. Opzs batteries used special filter and proof design to ensure no acid fog runs over and burning proof, and also convenient examine and maintenance.

Application

- | | |
|--------------------|---------------------------|
| Telecommunications | Medical Equipment |
| Cable Television | UPS |
| Electric Utility | Railroad Utility |
| Control Equipment | Photovoltaic System |
| Security System | Alternative Energy System |

General Features

- Maintenance convenient.
- Non-Spillable construction design.
- Transparent containers, convenient to observe.
- Special filter installation for acid fog proof.
- High quality and high reliability.
- Super long service life.
- Special pole sealed technology.
- Super reliability.

Construction

- | | | | |
|-----------|-------------------|-------------|--------------------|
| Component |Raw material | Terminal |Copper |
| Positive |Lead dioxide | Separator |Rubber-PVC |
| Negative |Lead | Electrolyte |Sulfuric acid |
| Container |AS | | |
| Cover |AS | | |

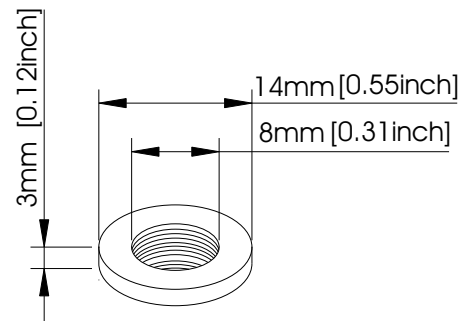

Terminal Dimensions

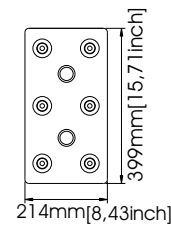
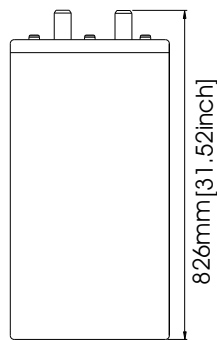

Battery Model	OPzS 2-2000			
Designed Floating Life	15 Years			
Capacity(25°C)	24HR(100A,1.85V)	10HR(200A,1.80V)	5HR(336A,1.77V)	1HR(992A,1.67V)
	2400AH	2000AH	1680AH	992AH
Dimensions	Length	Width	Height	Total Height
	399mm(15.71inch)	214mm(8.43inch)	771mm(30.35inch)	826mm(30.52inch)
Approx. Weight	Without electrolyte:123 Kg (271.2 lbs)		with electrolyte: 166 Kg(366.0 lbs)	
Internal Resistance	Full charged at 25°C: 0.0005 Ohm			
Self Discharge	3% of capacity declined per month at (25°C)			
Capacity Affected by Temp.(20HR)	40°C	25°C	0°C	-15°C
	102%	100%	85%	65%
Charge Voltage(25°C)	Cycle use		Float use	
	2.35V-2.4V(-5mV/ °C), max. Current: 300A		2.24V(-3.3mV/ °C)	

OPzS Series SLA Battery

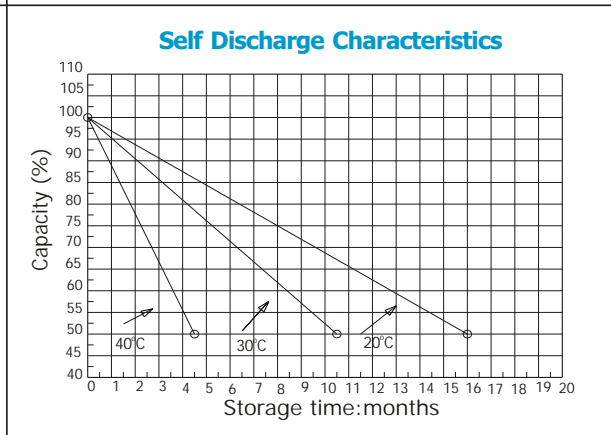
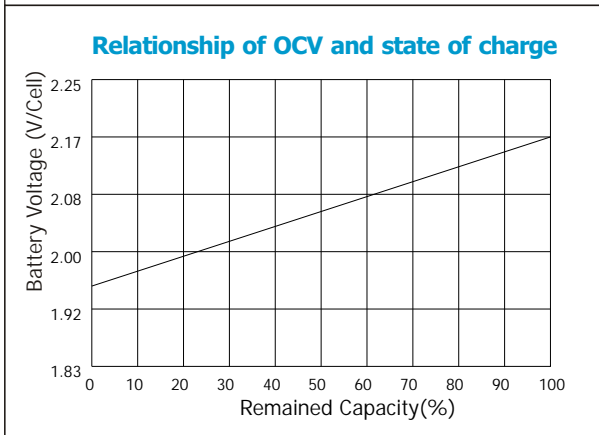
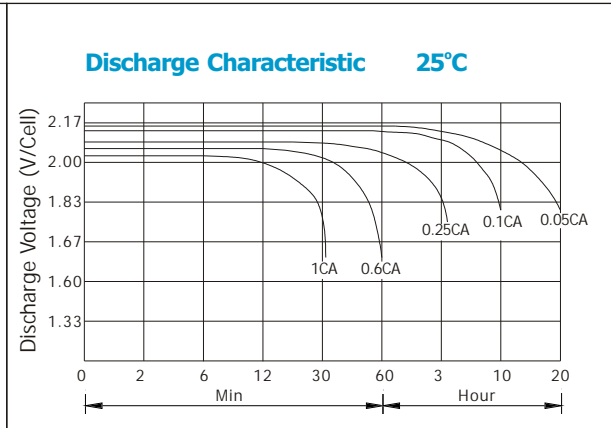
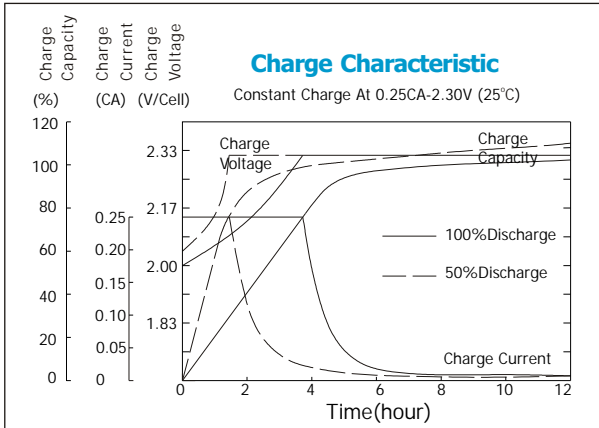

Constant current discharge ratings-amperes at 25°C

TIME	1HR	3HR	5HR	10HR	24HR	48HR	72HR	96HR	120HR	240HR
CUT-OFF VOLTAGE	1.67	1.75	1.77	1.80	1.85	1.85	1.85	1.85	1.85	1.85
CAPACITY(AH)	992	1488	1680	2000	2400	2680	2800	2810	2820	2880

Constant power discharge ratings-watts at 25°C

TIME	1HR	3HR	5HR	10HR	24HR	48HR	72HR	96HR	120HR	240HR
CUT-OFF VOLTAGE	1.67	1.75	1.77	1.80	1.85	1.85	1.85	1.85	1.85	1.85
CAPACITY(WH)	1309	2515	2789	3180	3504	3913	4088	4103	4117	4205

