

General Series

General Series Valve Regulated Lead Acid batteries are designed with AGM (Absorbent Glass Mat) technology, high performance plates and electrolyte to gain extra power output for common power backup system applications widely used in the field of UPS, Emergency Lighting System.

Application

- | | |
|-------------------------|------------------------|
| Alarm System | Medical Equipment |
| Cable Television | UPS |
| Communication Equipment | Power tools |
| Control Equipment | Emergency Power System |
| Security System | Toys |



General Features

- Sealed and maintenance free operation.
- Non-Spillable construction design.
- ABS containers and covers(UL94HB, UL94V-0) optional.
- Safety valve installation for explosion proof.
- High quality and high reliability.
- Exceptional deep discharge recovery performance.
- Low self discharge characteristic.
- Flexibility design for multiple install positions.

Construction

- | | | | |
|-----------------|--------------|--------------------|---------------|
| Component | Raw material | Sealant | Epoxy Resin |
| Positive | Lead dioxide | Safety valve | EPDR |
| Negative | Lead | Terminal | Copper |
| Container | ABS | Separator | Fiber glass |
| Cover | ABS | Electrolyte | Sulfuric acid |

Slide Contact Terminals

Terminal Dimensions

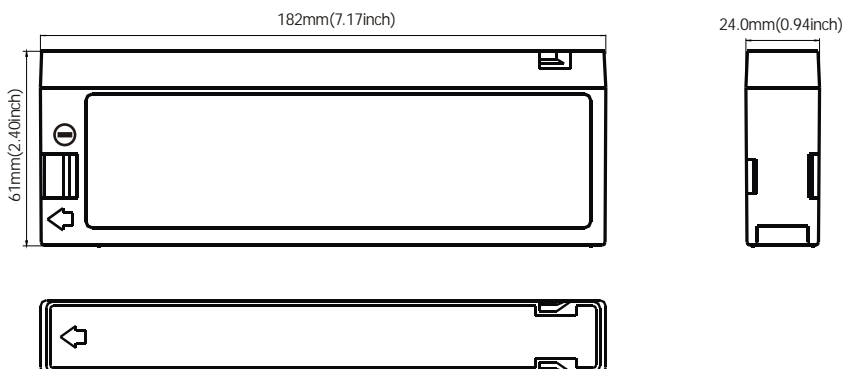

Battery Model	GB12-2.3C			
Designed Floating Life	5 Years			
Capacity(25°C)	20HR(0.115A,1.75V)	10HR(0.21A,1.75V)	5HR(0.39A,1.75V)	1HR(1.49A,1.75V)
	2.3AH	2.1AH	1.95AH	1.49AH
Dimensions	Length	Width	Height	Total Height
	182mm(7.17inch)	24mm(0.94inch)	61mm(2.40inch)	61mm(2.40inch)
Approx. Weight	0.77Kg (1.70 lbs)			
Internal Resistance	Full charged at 25°C: 0.06 Ohm			
Self Discharge	3% of capacity declined per month at (25°C)			
Capacity Affected by Temp.(20HR)	40°C	25°C	0°C	-15°C
	102%	100%	85%	65%
Charge Voltage(25°C)	Cycle use		Float use	
	14.4-15V(-30mV/ °C), max. Current: 0.69A		13.6-13.8V(-20mV/ °C)	

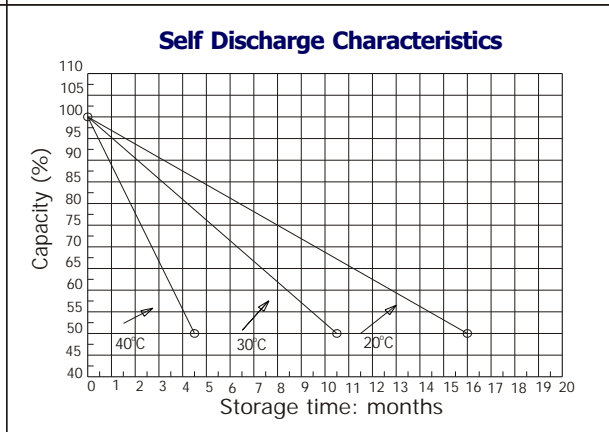
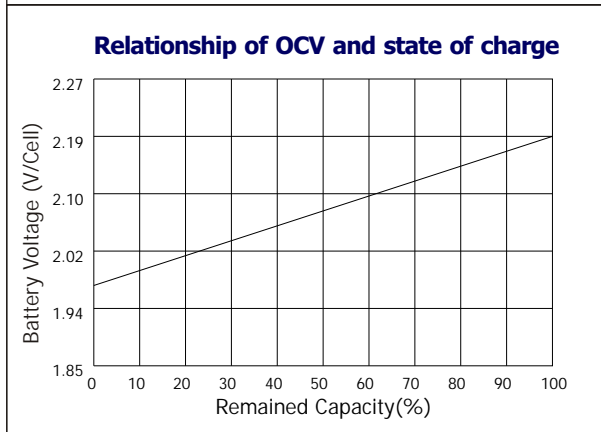
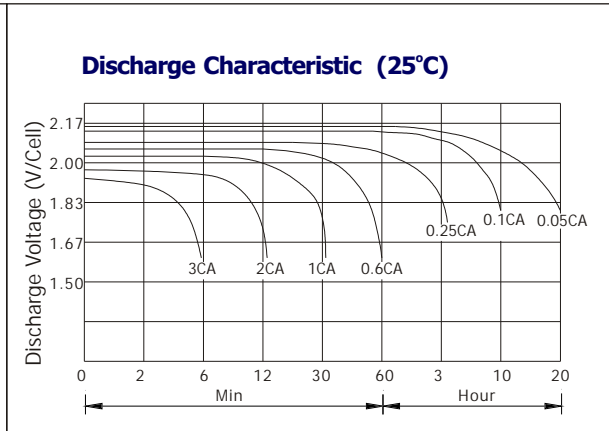
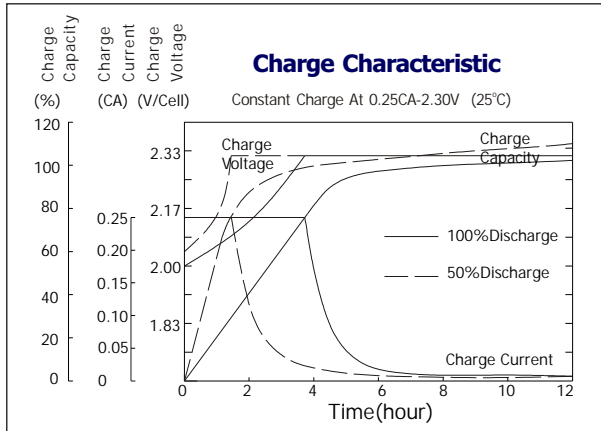

Constant current discharge ratings-amperes at 25°C

F.V / Time	5 MIN	10 MIN	15 MIN	30 MIN	1 HR	3 HR	5 HR	10 HR	20 HR
1.60V	8.99	5.59	4.22	2.57	1.63	0.72	0.44	0.25	0.13
1.67V	8.43	5.30	4.06	2.46	1.61	0.69	0.43	0.24	0.12
1.70V	7.73	5.11	3.96	2.24	1.56	0.64	0.42	0.24	0.12
1.75V	7.57	4.95	3.83	2.12	1.49	0.62	0.41	0.24	0.12
1.80V	6.78	4.73	3.48	1.97	1.40	0.60	0.39	0.24	0.12
1.85V	5.98	4.50	3.13	1.81	1.30	0.58	0.36	0.23	0.11

Constant power discharge ratings-watts at 25°C

F.V / Time	5 MIN	10 MIN	15 MIN	30 MIN	1 HR	3 HR	5 HR	10 HR	20 HR
1.60V	15.8	10.1	7.70	4.63	2.95	1.27	0.74	0.49	0.26
1.67V	15.2	9.84	7.60	4.54	2.93	1.23	0.74	0.49	0.25
1.70V	14.3	9.74	7.54	4.25	2.88	1.18	0.73	0.48	0.25
1.75V	14.4	9.71	7.48	4.12	2.83	1.15	0.72	0.48	0.24
1.80V	13.2	9.57	6.93	3.93	2.66	1.12	0.70	0.47	0.23
1.85V	12.0	9.08	6.29	3.68	2.51	1.08	0.68	0.47	0.22

