

General Series SLA Battery

**General Series**

General Series Valve Regulated Lead Acid batteries are designed with AGM (Absorbent Glass Mat) technology, high performance plates and electrolyte to gain extra power output for common power backup system applications widely used in the field of UPS, Emergency Lighting System.

**Application**

- |                         |                        |
|-------------------------|------------------------|
| Alarm System            | Medical Equipment      |
| Cable Television        | UPS                    |
| Communication Equipment | Power tools            |
| Control Equipment       | Emergency Power System |
| Security System         | Toys                   |



**General Features**

- Sealed and maintenance free operation.
- Non-Spillable construction design.
- ABS containers and covers(UL94HB, UL94V-0) optional.
- Safety valve installation for explosion proof.
- High quality and high reliability.
- Exceptional deep discharge recovery performance.
- Low self discharge characteristic.
- Flexibility design for multiple install positions.

**Construction**

- |           |                   |              |                    |
|-----------|-------------------|--------------|--------------------|
| Component | .....Raw material | Sealant      | .....Epoxy Resin   |
| Positive  | .....Lead dioxide | Safety valve | .....EPDR          |
| Negative  | .....Lead         | Terminal     | .....Copper        |
| Container | .....ABS          | Separator    | .....Fiber glass   |
| Cover     | .....ABS          | Electrolyte  | .....Sulfuric acid |

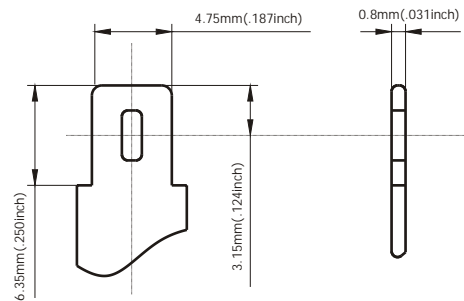

**Terminal Dimensions**

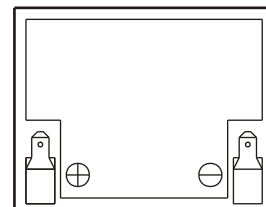
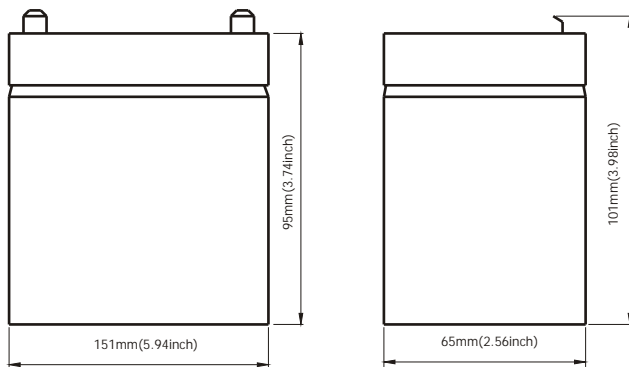

Battery Model	GB 12-6.5			
Designed Floating Life	5 Years			
Capacity(25°C)	20HR(0.325A,1.75V)	10HR(0.62A,1.75V)	5HR(1.1A,1.75V)	1HR(4.2A,1.75V)
	6.5AH	6.2AH	5.5AH	4.2AH
Dimensions	Length	Width	Height	Total Height
	151mm(9.54inch)	65mm(2.56inch)	95mm(3.74inch)	101mm(3.98inch)
Approx. Weight	2Kg (4.41 lbs)			
Internal Resistance	Full charged at 25°C: 0.025 Ohm			
Self Discharge	3% of capacity declined per month at (25°C)			
Capacity Affected by Temp.(20HR)	40°C	25°C	0°C	-15°C
	102%	100%	85%	65%
Charge Voltage(25°C)	Cycle use		Float use	
	14.4-15V(-30mV/ °C), max. Current: 1.95A		13.6-13.8V(-20mV/ °C)	

General Series SLA Battery

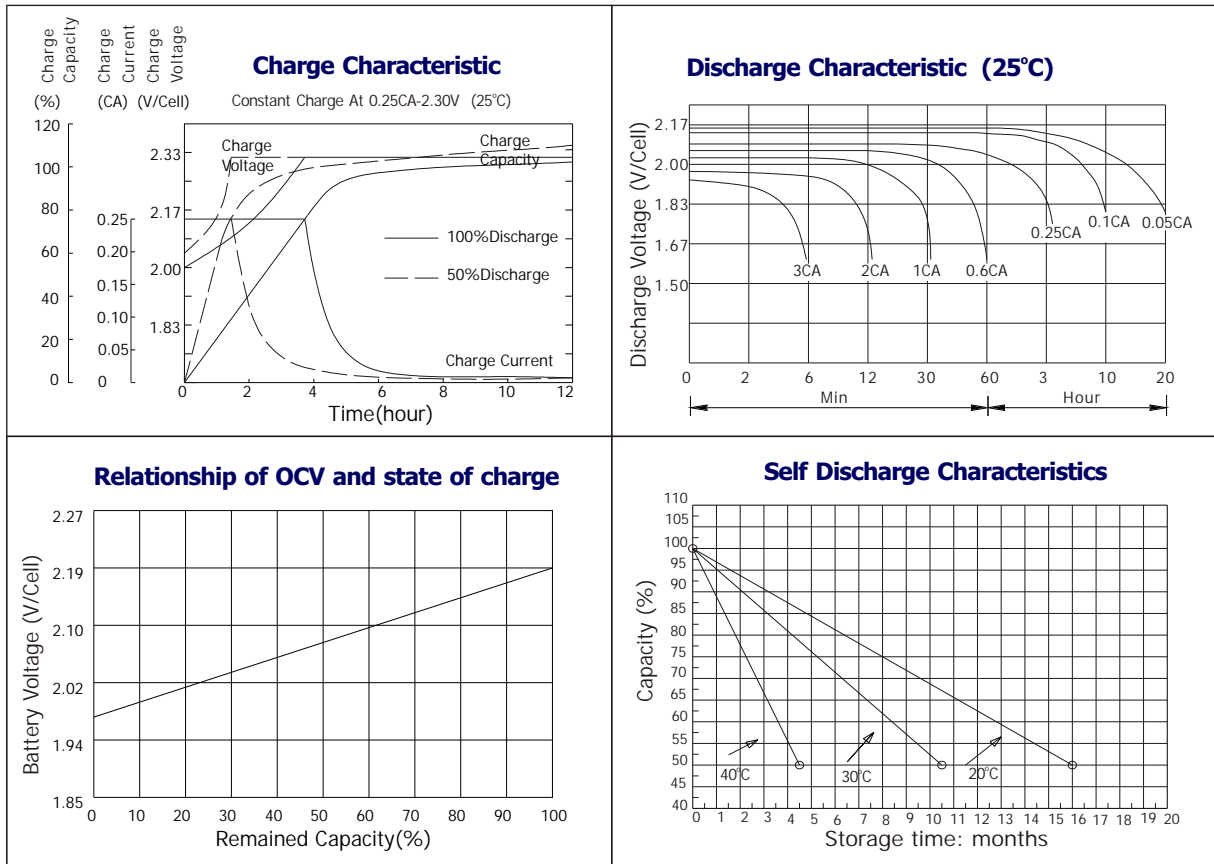

**Constant current discharge ratings-amperes at 25°C**

F.V/T ime	5 MIN	10 MIN	15 MIN	30 MIN	1 HR	3 HR	5 HR	10 HR	20 HR
1.60V	21.9	13.6	10.3	6.26	3.98	1.75	1.07	0.60	0.31
1.67V	20.5	12.9	9.88	5.99	3.93	1.68	1.05	0.59	0.30
1.70V	18.8	12.4	9.64	5.44	3.81	1.57	1.02	0.59	0.30
1.75V	18.4	12.1	9.33	5.17	3.63	1.52	1.00	0.58	0.29
1.80V	16.5	11.5	8.48	4.79	3.40	1.46	0.94	0.57	0.28
1.85V	14.6	11.0	7.62	4.41	3.17	1.40	0.88	0.57	0.27

**Constant power discharge ratings-watts at 25°C**

F.V/T ime	5 MIN	10 MIN	15 MIN	30 MIN	1 HR	3 HR	5 HR	10 HR	20 HR
1.60V	38.4	24.6	18.7	11.3	7.18	3.10	1.80	1.19	0.63
1.67V	37.0	24.0	18.5	11.0	7.14	3.00	1.80	1.19	0.60
1.70V	34.9	23.7	18.4	10.3	7.00	2.87	1.77	1.18	0.60
1.75V	35.1	23.6	18.2	10.0	6.88	2.80	1.76	1.16	0.58
1.80V	32.1	23.3	16.9	9.57	6.49	2.72	1.70	1.15	0.57
1.85V	29.1	22.1	15.3	8.96	6.10	2.64	1.65	1.13	0.55

