

OPzV Series SLA Battery

Opzv Series

Bosfa Opzv Series Valve Regulated Lead Acid batteries are designed with a proven combination of GEL and Tubular technologies to offer a very high lever of reliability. Opzv batteries benefit from an optimized plate design which gives capacities in excess of the DIN standard values. In addition, this series offers both a longest float life and a high cycle life in widely industrial field.

Application

- | | |
|--------------------|---------------------------|
| Telecommunications | Medical Equipment |
| Cable Television | UPS |
| Electric Utility | Railroad Utility |
| Control Equipment | Photovoltaic System |
| Security System | Alternative Energy System |



General Features

- Sealed and maintenance free operation.
- Non-Spillable construction design.
- ABS containers and covers(UL94HB, UL94V-0) optional.
- Safety valve installation for explosion proof.
- High quality and high reliability.
- Super long service life.
- Lowest self discharge characteristic.
- Super reliability.

Construction

- | | | | |
|-----------|-------------------|--------------|---------------------------------------|
| Component |Raw material | Sealant |Epoxy Resin |
| Positive |Lead dioxide | Safety valve |EPDR |
| Negative |Lead | Terminal |Copper |
| Container |ABS | Separator |PVC-SiO2 |
| Cover |ABS | Electrolyte |Sulfuric acid
Thixotropic Gel |

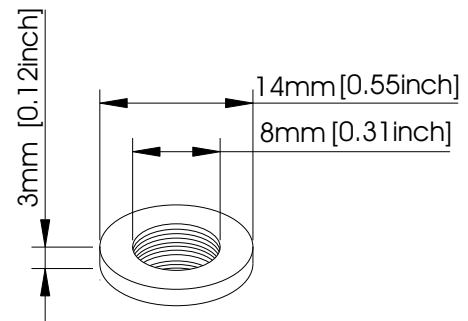

Terminal Dimensions

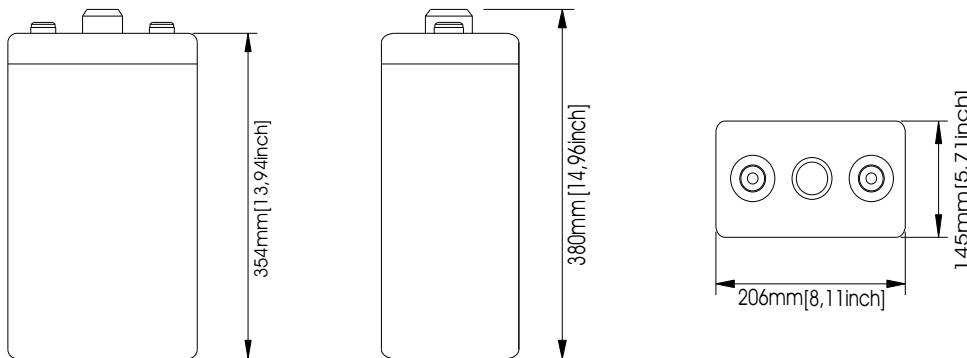

Battery Model	OPzV 2-300			
Designed Floating Life	15 Years			
Capacity(25°C)	20HR(15.5A,1.75V)	10HR(30A,1.75V)	5HR(54.2A,1.75V)	1HR(202A,1.75V)
	310AH	300AH	271AH	202AH
Dimensions	Length	Width	Height	Total Height
	145mm(5.71inch)	206mm(8.11inch)	354mm(13.94inch)	380mm(14.96inch)
Approx. Weight	29Kg (63.95 lbs)			
Internal Resistance	Full charged at 25°C: 0.00075 Ohm			
Self Discharge	3% of capacity declined per month at (25°C)			
Capacity Affected by Temp.(20HR)	40°C	25°C	0°C	-15°C
	102%	100%	85%	65%
Charge Voltage(25°C)	Cycle use		Float use	
	2.3V-2.35V(-5mV/ °C), max. Current: 60A		2.25-2.27V(-3.3mV/ °C)	

OPzV Series SLA Battery

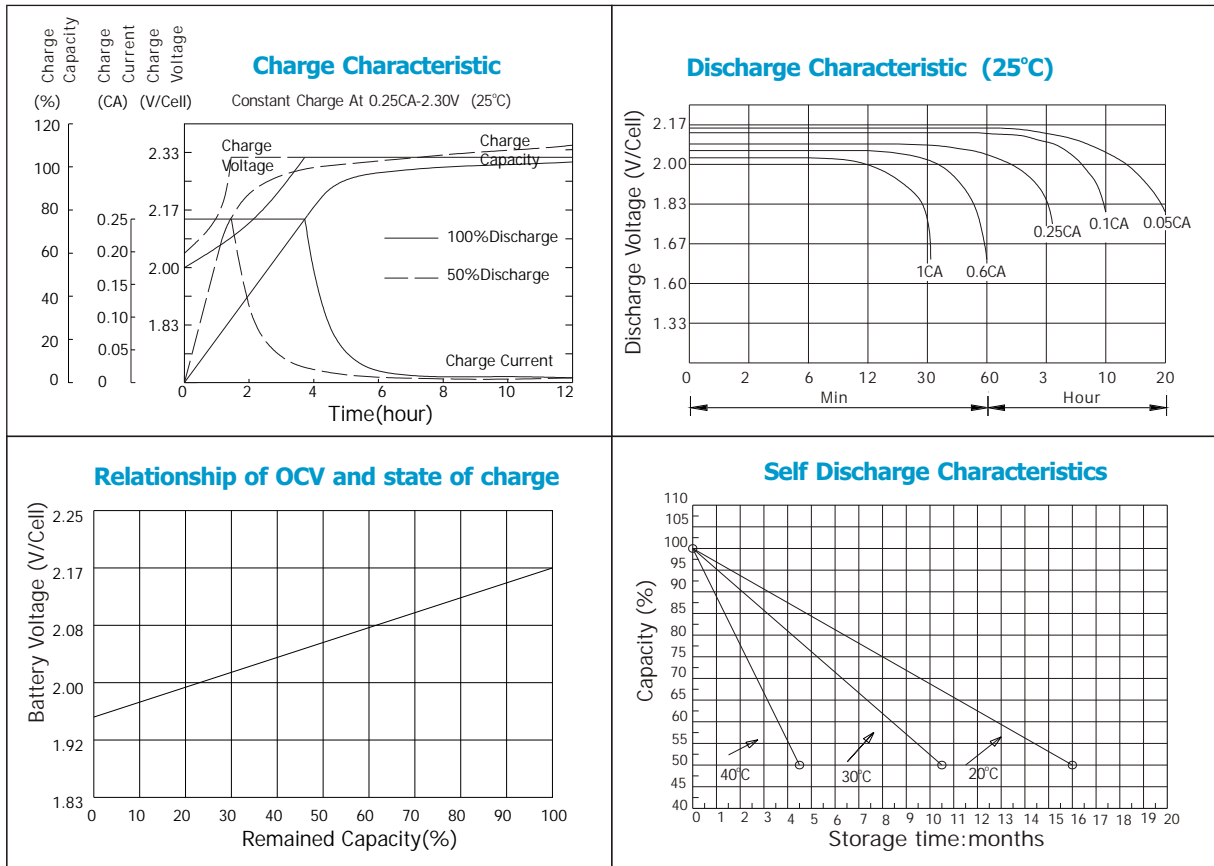

Constant current discharge ratings-amperes at 25°C

F.V/Time	15MIN	30MIN	1HR	2HR	3HR	5HR	8HR	10HR	20HR
1.70V	375	258	166	100.5	75.0	51.0	36.0	30.5	19.3
1.75V	341	247	165	98.4	75.0	51.0	36.0	30.0	19.0
1.80V	303	231	153	95.5	75.0	49.8	34.8	30.0	19.1
1.83V	279	219	148	93.0	70.2	49.0	34.5	29.0	18.4
1.87V	245	198	137	88.0	67.0	47.8	32.5	28.0	18.4
1.90V	221	180	128	82.5	63.0	45.0	31.0	26.5	17.2

Constant power discharge ratings-watts at 25°C

F.V/Time	15MIN	30MIN	1HR	2HR	3HR	5HR	8HR	10HR	20HR
1.70V	624	444	348	184	151	112	76.9	62.7	39.7
1.75V	550	433	315	179	151	111	76.0	60.8	38.5
1.80V	489	416	293	182	148	106	72.6	60.2	38.4
1.83V	466	391	280	178	146	105	71.7	57.8	36.7
1.87V	400	341	259	173	143	103	68.8	56.4	37.0
1.90V	393	332	255	165	135	98.8	64.6	53.7	34.9

