

**OPzV Series SLA Battery**

**Opzv Series**

Bosfa Opzv Series Valve Regulated Lead Acid batteries are designed with a proven combination of GEL and Tubular technologies to offer a very high lever of reliability. Opzv batteries benefit from an optimized plate design which gives capacities in excess of the DIN standard values. In addition, this series offers both a longest float life and a high cycle life in widely industrial field.

**Application**

- |                    |                           |
|--------------------|---------------------------|
| Telecommunications | Medical Equipment         |
| Cable Television   | UPS                       |
| Electric Utility   | Railroad Utility          |
| Control Equipment  | Photovoltaic System       |
| Security System    | Alternative Energy System |

**General Features**

- Sealed and maintenance free operation.
- Non-Spillable construction design.
- ABS containers and covers(UL94HB, UL94V-0) optional.
- Safety valve installation for explosion proof.
- High quality and high reliability.
- Super long service life.
- Lowest self discharge characteristic.
- Super reliability.

**Construction**

- |           |                   |              |                           |
|-----------|-------------------|--------------|---------------------------|
| Component | .....Raw material | Sealant      | .....Epoxy Resin          |
| Positive  | .....Lead dioxide | Safety valve | .....EPDR                 |
| Negative  | .....Lead         | Terminal     | .....Copper               |
| Container | .....ABS          | Separator    | .....PVC-SiO <sub>2</sub> |
| Cover     | .....ABS          | Electrolyte  | .....Sulfuric acid        |
|           |                   |              | Thixotropic Gel           |

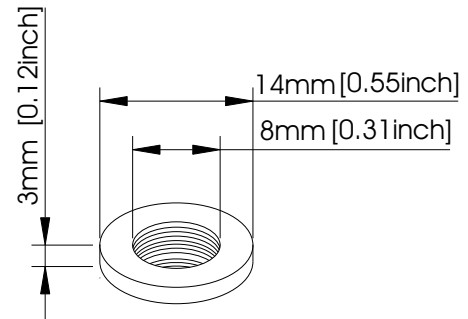

**Terminal Dimensions**

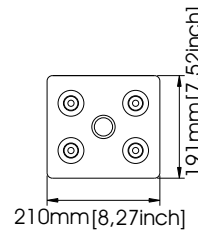
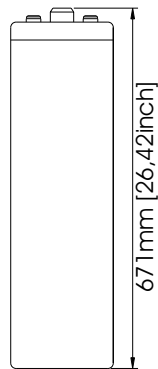

Battery Model	OPzV 2-800			
Designed Floating Life	15 Years			
Capacity(25°C)	20HR(41A,1.75V)	10HR(80A,1.75V)	5HR(146A,1.75V)	1HR(516A,1.75V)
	820AH	800AH	730AH	516AH
Dimensions	Length	Width	Height	Total Height
	191mm(7.52inch)	210mm(8.27inch)	645mm(25.39inch)	671mm(26.42inch)
Approx. Weight	68Kg (149.94 lbs)			
Internal Resistance	Full charged at 25°C: 0.0006 Ohm			
Self Discharge	3% of capacity declined per month at (25°C)			
Capacity Affected by Temp.(20HR)	40°C	25°C	0°C	-15°C
	102%	100%	85%	65%
Charge Voltage(25°C)	Cycle use		Float use	
	2.3V-2.35V(-5mV/ °C), max. Current: 160A		2.25-2.27V(-3.3mV/ °C)	

**OPzV Series SLA Battery**

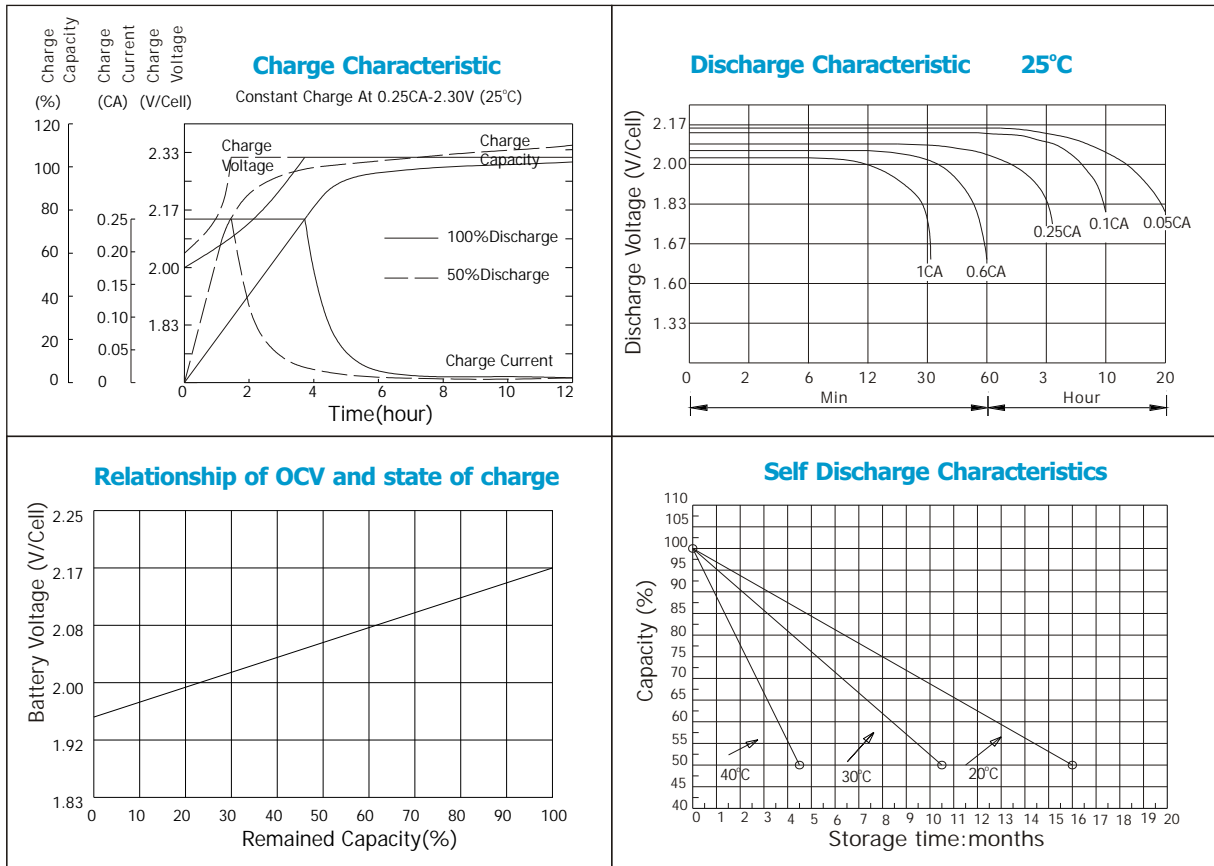

**Constant current discharge ratings-amperes at 25°C**

F.V/Time	15MIN	30MIN	1HR	2HR	3HR	5HR	8HR	10HR	20HR
1.70V	848	688	468	286	212	142	97.6	82.0	46.4
1.75V	752	624	448	278	208	141	97.6	81.0	45.9
1.80V	656	560	416	266	200	139	96.0	80.0	45.9
1.83V	592	504	384	256	195	136	94.0	78.0	45.2
1.87V	480	440	344	236	183	130	89.6	74.5	44.3
1.90V	416	392	312	220	172	124	86.0	71.5	42.1

**Constant power discharge ratings-watts at 25°C**

F.V/Time	15MIN	30MIN	1HR	2HR	3HR	5HR	8HR	10HR	20HR
1.70V	1462	1190	849	542	427	293	194	158	89.7
1.75V	1346	1142	884	528	417	289	191	156	88.3
1.80V	1192	1074	779	514	402	284	189	154	88.2
1.83V	1096	919	718	490	396	269	179	151	87.2
1.87V	1038	870	699	490	389	267	174	146	86.7
1.90V	861	799	635	472	353	256	167	138	81.6

