

OPzV Series SLA Battery

Opzv Series

Bosfa Opzv Series Valve Regulated Lead Acid batteries are designed with a proven combination of GEL and Tubular technologies to offer a very high lever of reliability. Opzv batteries benefit from an optimized plate design which gives capacities in excess of the DIN standard values. In addition, this series offers both a longest float life and a high cycle life in widely industrial field.

Application

- | | |
|--------------------|---------------------------|
| Telecommunications | Medical Equipment |
| Cable Television | UPS |
| Electric Utility | Railroad Utility |
| Control Equipment | Photovoltaic System |
| Security System | Alternative Energy System |

General Features

- Sealed and maintenance free operation.
- Non-Spillable construction design.
- ABS containers and covers(UL94HB, UL94V-0) optional.
- Safety valve installation for explosion proof.
- High quality and high reliability.
- Super long service life.
- Lowest self discharge characteristic.
- Super reliability.

Construction

- | | | | |
|-----------|-------------------|--------------|---------------------------|
| Component |Raw material | Sealant |Epoxy Resin |
| Positive |Lead dioxide | Safety valve |EPDR |
| Negative |Lead | Terminal |Copper |
| Container |ABS | Separator |PVC-SiO ₂ |
| Cover |ABS | Electrolyte |Sulfuric acid |
| | | | Thixotropic Gel |

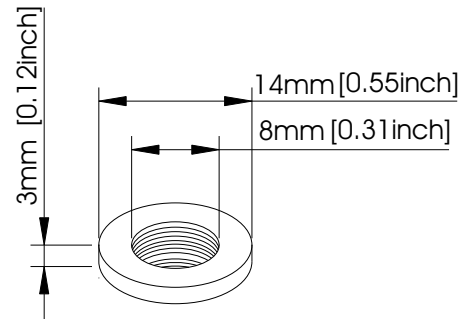

Terminal Dimensions

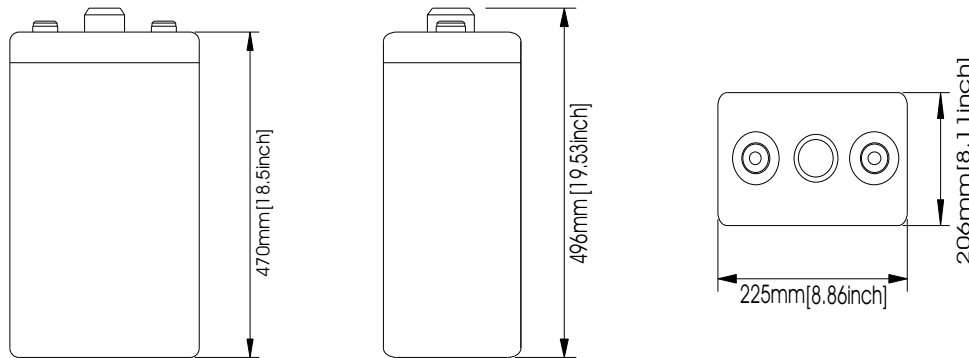

Battery Model	OPzV 2-630			
Designed Floating Life	15 Years			
Capacity(25°C)	20HR(32.5A,1.75V)	10HR(63A,1.75V)	5HR(107A,1.75V)	1HR(399A,1.75V)
	650AH	630AH	535AH	399AH
Dimensions	Length	Width	Height	Total Height
	225mm(8.86inch)	206mm(8.11inch)	470mm(18.51inch)	496mm(19.53inch)
Approx. Weight	38.0 Kg (83.8 lbs)			
Internal Resistance	Full charged at 25°C: 0.00063 Ohm			
Self Discharge	3% of capacity declined per month at (25°C)			
Capacity Affected by Temp.(20HR)	40°C	25°C	0°C	-15°C
	102%	100%	85%	65%
Charge Voltage(25°C)	Cycle use		Float use	
	2.3V-2.35V(-5mV/ °C), max. Current: 120A		2.25-2.27V(-3.3mV/ °C)	

OPzV Series SLA Battery

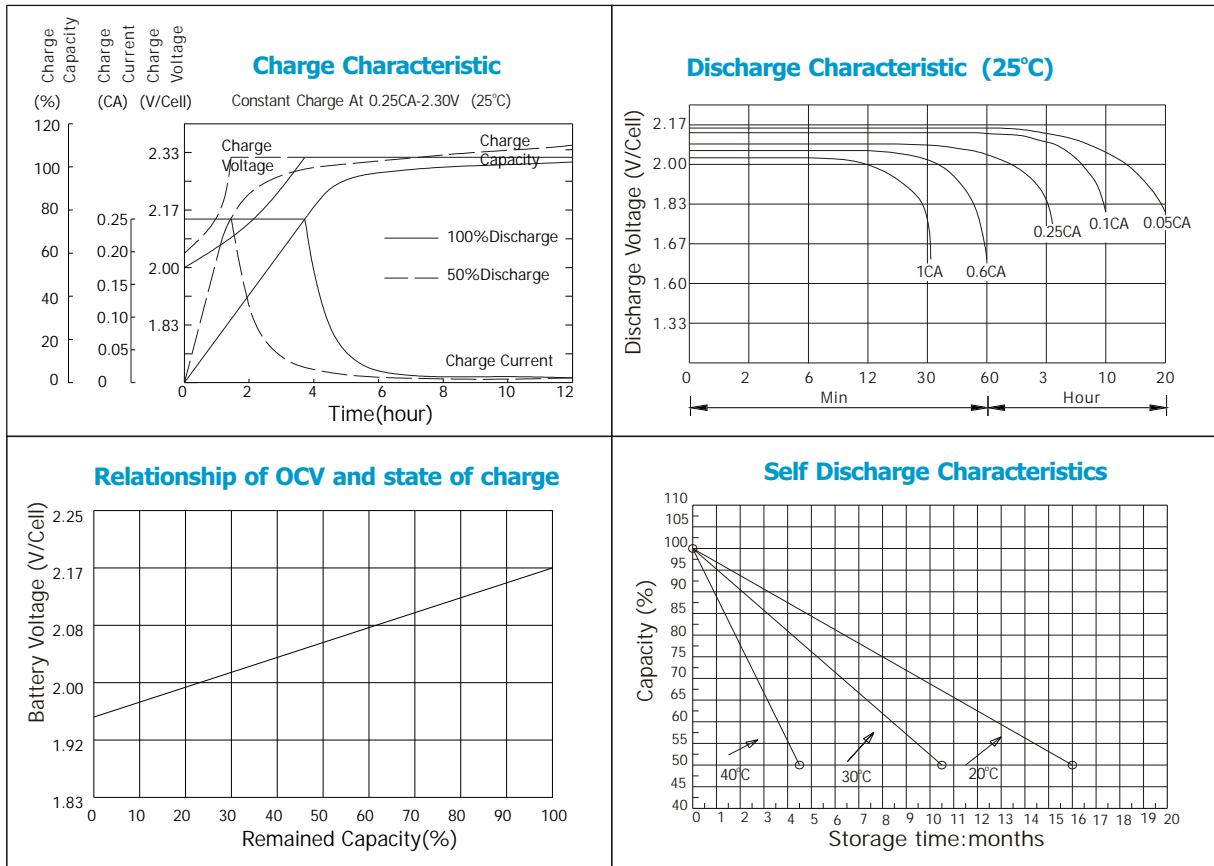

Constant current discharge ratings-amperes at 25°C

F.V/Time	15MIN	30MIN	1HR	2HR	3HR	5HR	8HR	10HR	20HR
1.70V	668	542	369	254	167	112	77.0	65.0	33.2
1.75V	592	491	353	219	164	111	76.8	64.0	32.5
1.80V	517	441	328	210	158	109	76.0	63.0	32.1
1.83V	467	397	303	202	153	107	74.0	61.5	31.3
1.87V	378	347	271	186	144	102.0	70.5	58.0	29.5
1.90V	328	309	246	173	136	97.0	68.0	56.0	28.5

Constant power discharge ratings-watts at 25°C

F.V/Time	15MIN	30MIN	1HR	2HR	3HR	5HR	8HR	10HR	20HR
1.70V	941	902	613	478	351	206	140	116	58.2
1.75V	826	794	572	412	353	203	138	113	56.5
1.80V	737	695	525	384	324	196	133	107	53.4
1.83V	754	716	560	396	317	196	128	100	50.0
1.87V	683	703	570	390	300	189	120	89.5	45.2
1.90V	655	697	577	386	286	182	114	82.2	41.7

